

Rectifier

Variable ratio transformer and Thyristor Technology

Rectifiers

oil-cooled and oil-water-cooled



Oil Cooling

Oil-Water Cooling

This design is still a strong and reliable basis for applications under difficult industrial conditions. The adjustment of the rectifier can be carried out by means of a motor-driven variable ratio transformer or electronically by means of thyristors.

Product Advantages

- Robust construction for aggravating industrial applications
- High safety
- High protection grade IP 54

Remote control (higher / lower)

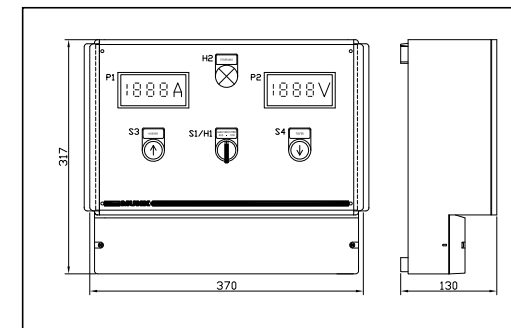

Remote control (with constant current or voltage control):

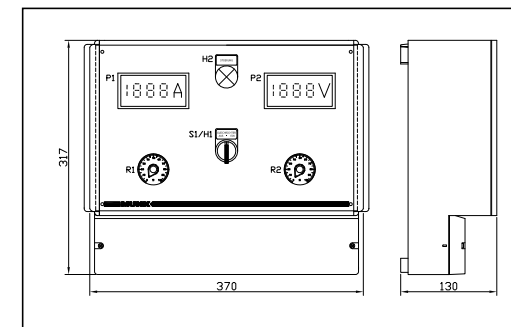

Measuring Instruments (standard)

- Digital for current and voltage

Further Options

- Remote control (standard)
- Phase protection
- Ah counter
- Special controls
- Constant current or voltage control
- Polarity inverter (electronic or mechanical)
- Field bus interface
- Silikagel air de-hydration
- Smoothing choke to reduce the ripple (for thyristor technology)

Technical Data (standard)

Mains voltage	3 x 400 V/50 Hz + N + PE (further voltages on request)
Adjustment	stepless from 0 - 100 %
Ripple: Variable ratio transformer Thyristor technology	5 % full range approx. 5 - 7 % at full load
Duty factor	100 % ED
Ambient temperature	+ 35 °C
Water entry temperature (only for type OWA)	+ 16 °C up to + 30 °C
Insulating oil	accord. to IEC Publication 2/96 or DIN 57370 part 1 or VDE 0370 part 1
Operating altitude	up to 1000 m above sea level
Surface finish	Structural lacquer RAL 7032
Supervision	Oil temperature, overcurrent relay
Protection grade	IP 54 / IP 21

Technical changes reserved.



Stromrichtergeräte, Transformatoren und Elektroanlagen

MUNK GmbH
Gewerbepark 8 + 10
D-59069 Hamm-Rhynern
Tel +49 2385 74-0
Fax +49 2385 74-55
sales@rectifier.com

MUNK Service-Center-East
Bahnhofstrasse 39
D-09648 Mittweida
Tel +49 2385 74-20
Fax +49 2385 74-9920
service-ost@munk.de

MUNK Nederland BV
De Scheper 314a
NL-5688 HP Oirschot
Tel +31 499 582 180
Fax +31 499 582 185
sales@munk-nl.com

MUNK Service-Center-East
Bahnhofstrasse 39
D-09648 Mittweida
Tel +49 2385 74-20
Fax +49 2385 74-9920
service-ost@munk.de

www.rectifier.com

Rectifiers Type OS oil-cooled

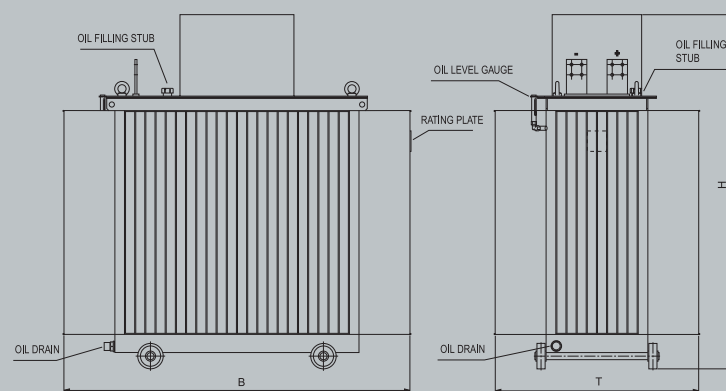

The main components are built into a corrugated steel tank. Due to the high protection grade (IP 54) the device can be located directly in an aggressive environment. The heat loss is convected by means of the corrugated surface.

OS rectifier available types (tank/ weight empty [kg])

I/A	6V	8V	10V	12V	15V	18V	20V	22V
100	F1/150	F1/165	F1/180	F1/190	F1/205	F1/215	F2/230	F2/240
200	F1/210	F1/225	F2/235	F2/245	F2/260	F2/270	F2/285	F2/295
300	F1/220	F2/235	F2/265	F2/295	F2/310	F3/330	F3/350	F3/370
400	F2/260	F2/280	F2/295	F2/315	F2/360	F3/380	F3/395	F3/370
500	F2/280	F2/305	F2/330	F2/360	F2/380	F3/390	F3/410	F3/430
600	F2/295	F2/315	F2/355	F2/370	F3/395	F4/415	F4/440	F4/460
800	F3/330	F3/360	F3/385	F3/410	F4/430	F5/460	F5/490	F5/515
1000	F3/380	F3/395	F3/415	F3/440	F4/470	F6/495	F6/530	F6/560
1200	F4/480	F4/510	F4/540	F4/660	F4/690	F8/710	F8/730	F8/760
1500	F4/610	F5/640	F6/680	F6/730	F8/770	F9/810	F9/850	F10/1070
2000	F6/690	F6/710	F7/750	F7/810	F9/850	F9/910	F9/1000	F11/1200
2500	F8/740	F8/760	F8/830	F8/880	F9/1010	F11/1180	F11/1270	F12/1360
3000	F9/965	F9/1015	F9/1110	F9/1190	F10/1240	F12/1520	F12/1670	F12/1750
4000	F10/1270	F10/1290	F10/1390	F10/1510	F12/1730	F12/1760	F13/1970	F13/2100
5000	F11/1530	F12/1580	F12/1650	F12/1780	F13/1910	F13/1910	F13/2160	F13/2240
6000	F12/1550	F12/1590	F13/1780	F13/1870	F13/1950	F14/2080	F14/2250	F14/2400
7000	F12/1580	F13/1650	F13/1870	F13/1920	F14/2040	F14/2140	F14/2500	F14/2650
8000	F13/1640	F13/1790	F14/1940	F14/2370	F15/2550	F16/2990	F16/3400	F16/3650
9000	F13/1750	F14/1880	F15/2050	F16/2430	F16/3280	F17/3450	F17/3900	F17/4100
10000	F14/1830	F15/1910	F15/2300	F16/2480	F16/3690	F17/4100	F17/4700	F17/4900
12000	F15/1950	F16/2200	F17/3150	F17/4500	F17/4800	F18/5050	F18/5300	
15000	F16/3900	F17/4000	F17/4900	F17/5120	F18/5700			

OS tank type [dimensions in mm]

Type	W	D	H	Oil requirement
F1	810	490	1120	160 kg
F2	950	570	1210	210 kg
F3	1150	580	1320	290 kg
F4	1270	610	1620	440 kg
F5	1330	670	1620	460 kg
F6	1370	710	1570	480 kg
F7	1430	770	1590	500 kg
F8	1540	800	1590	580 kg
F9	1580	880	1640	660 kg

OS tank type [dimensions in mm]

Type	W	D	H	Oil requirement
F10	1700	1000	1640	710 kg
F11	2050	1130	1740	930 kg
F12	2150	1180	1890	1150 kg
F13	1920	1610	2060	1850 kg
F14	2480	1480	2170	2750 kg
F15	2600	1600	2170	2900 kg
F16	2700	1700	2170	2960 kg
F17	2800	2100	2170	4100 kg
F18	2950	2100	2420	4830 kg

Rectifiers Type OWA oil-water-cooled

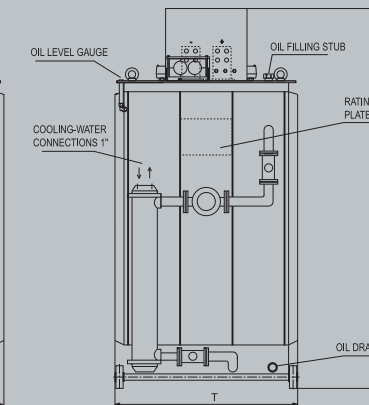
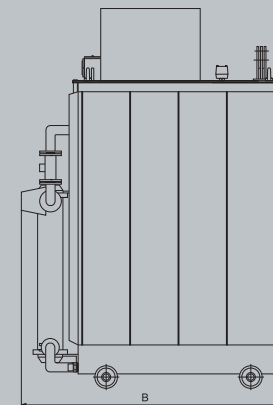

This design allows a more compact integration of high power. The smooth steel tank contains all power components and dissipates a low amount of the heat loss. By means of heat exchanger and circulation pump the main amount of the heat loss is given to the cooling circuit.

OWA rectifier-overview of model (tank/weight empty [kg])

I/A	6V	8V	10V	12V	15V	18V	20V	22V
4000	G01/1300	G01/1380	G01/1580	G01/1660	G01/1710	G01/1810	G01/1870	G01/2000
5000	G01/1360	G01/1440	G01/1660	G01/1710	G01/1760	G01/1860	G01/1920	G02/2050
6000	G01/1460	G01/1540	G01/1730	G01/1820	G01/1900	G01/2030	G01/2100	G02/2350
7000	G01/1530	G01/1600	G01/1820	G01/1870	G02/1990	G02/2090	G02/2250	G03/2500
8000	G01/1610	G01/1740	G02/1890	G02/2020	G02/2100	G04/2250	G04/2350	G04/2600
9000	G01/1750	G02/1830	G02/2000	G03/2080	G03/2230	G05/2400	G05/2500	G05/2730
10000	G01/1780	G02/1860	G02/2050	G03/2130	G03/2340	G05/2550	G05/2600	G05/2850
12000	G04/1900	G04/2150	G05/2300	G05/2450	G05/2750	G05/3000	G05/3250	o.r.
15000	G04/2450	G05/2750	G03/3000	G05/3250	G05/3650	on request		o.r.

Assessing of copper connection cross-section for OS and OWA [dimensions in mm]

DC output bars		
DC-current [A]	Qty	CU-cross-section
200	1	30 x 10
400	1	30 x 10
600	1	30 x 10
800	1	40 x 10
900	1	60 x 10
1200	1	60 x 10
1500	1	80 x 10
2000	1	100 x 10
2500	1	120 x 10
3000	2	100 x 10

DC output bars		
DC-current [A]	Qty	CU-cross-section
4000	2	100 x 10
5000	2	120 x 10
6000	2	160 x 10
7000	4	100 x 10
8000	4	120 x 10
9000	4	120 x 10
10000	6	100 x 10
12000	6	100 x 10
14000	6	120 x 10
15000	6	120 x 10

OWA tank type [dimensions in mm]

Type	W	D	H	Oil requirement
G01	1455	1100	2200	1400 kg
G02	1480	1210	2230	1500 kg
G03	1570	1250	2280	1800 kg
G04	2000	1100	2200	1920 kg
G05	2400	1450	2200	3240 kg

Rule of thumb to determine the amount cooling water for OWA

rated DC current [A] x 0,22 [¹/A] at Δ T= 10K;
 ≙ Amount of water in litres per hour
 e.g. current 10,000A x 0,22 [¹/A]
 ≙ ≧ 2,200 litres per hour